

LINTEL FIXING SCHEDULE ALTERNATIVE TO TABLE 8.14 & FIGURE 8.12 NZS 3604:2011

NOTE:

- ★ All fixings are designed for vertical loads only. Dead loads include the roof weight and standard ceiling weight of 0.20kPa.
- ★ Refer to Table 8.19 NZS 3604:2011 for nailing schedule to resist horizontal loads.
- ★ These fixings assume the correct choice of rafter/truss to top plate connections have been made.
- ★ All fixings assume bottom plate thickness of 45mm maximum. Note: TYLOK options on timber species.
- ★ Wall framing arrangements under girder trusses are not covered in this schedule.
- ★ All timber selections are as per NZS 3604:2011.

DEFINITIONS

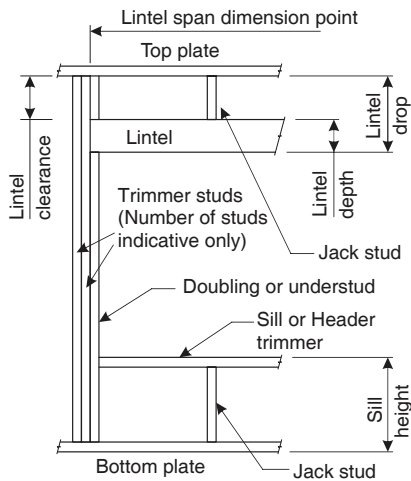

Lintel Supporting Girder Trusses						
Roof Tributary Area	Light Roof			Heavy Roof		
	Wind Zone			Wind Zone		
	L, M, H	VH	EH	L, M, H	VH	EH
8.6m ²	G	G	H	G	G	H
11.6m ²	G	H	H	G	G	H
12.1m ²	G	H	H	G	H	H
15.3m ²	H	H	-	G	H	H
19.1m ²	H	-	-	G	H	-
20.9m ²	H	-	-	H	H	-
21.8m ²	H	-	-	H	-	-
34.3m ²	-	-	-	H	-	-

NOTES:

1. Roof Tributary Area = approx. 1/2 x (Total roof area on girder and rafter trusses supported by lintel)
2. Assumed girder truss is at mid-span or middle third span of lintel
3. Use similar fixings for both ends of lintel
4. All other cases require specific engineering design

Lintel Span (m)	Loaded Dimension (m) (See Fig. 1.3 NZS 3604:2011)	Light Roof Wind Zone					Heavy Roof Wind Zone				
		L	M	H	VH	EH	L	M	H	VH	EH
1.0	2.0	E	E	E	F	F	E	E	E	E	F
	3.0	E	E	F	F	F	E	E	E	F	F
	4.0	E	F	F	F	G	E	E	E	F	F
	5.0	E	F	F	G	G	E	E	F	F	G
	6.0	E	F	F	G	G	E	E	F	F	G
1.2	2.0	E	E	F	F	F	E	E	E	F	F
	3.0	E	E	F	F	F	E	E	F	F	F
	4.0	E	F	F	G	G	E	E	F	F	G
	5.0	E	F	F	G	G	E	E	F	F	G
1.5	2.0	E	E	F	F	F	E	E	E	F	F
	3.0	E	F	F	F	G	E	E	F	F	F
	4.0	E	F	F	G	G	E	E	F	F	G
	5.0	F	F	G	G	H	E	E	F	G	G
2.0	2.0	E	E	F	F	F	E	E	E	F	F
	3.0	E	F	F	G	G	E	E	F	F	G
	4.0	F	F	G	G	H	E	E	F	G	G
	5.0	F	F	G	H	H	E	E	F	G	H
2.4	2.0	E	F	F	G	G	E	E	F	F	G
	3.0	F	F	G	H	H	E	E	F	G	G
	4.0	F	F	G	H	H	E	E	F	G	H
	5.0	F	G	G	H	H	E	F	G	H	H
3.0	2.0	E	F	F	G	G	E	E	F	F	G
	3.0	F	F	G	H	H	E	E	F	G	H
	4.0	F	G	G	H	H	E	F	G	H	H
	5.0	F	G	H	-	-	E	F	G	H	-
3.6	2.0	F	F	G	G	H	E	E	F	G	G
	3.0	F	F	G	H	H	E	F	G	G	H
	4.0	F	G	H	-	-	E	F	G	H	H
	5.0	F	G	H	-	-	E	F	G	H	-
4.2	2.0	F	F	G	G	H	E	E	F	G	G
	3.0	F	G	H	H	-	E	F	G	H	H
	4.0	F	G	H	-	-	E	F	G	H	-
	5.0	G	H	H	-	-	E	F	H	-	-
4.5	2.0	F	F	G	H	H	E	E	F	G	H
	3.0	F	G	H	H	-	E	F	G	H	H
	3.4	F	G	H	H	-	E	F	G	H	H
	4.0	F	G	H	-	-	E	F	G	H	-
4.8	2.0	F	F	G	H	H	E	E	F	G	H
	3.0	F	G	H	H	-	E	F	G	H	H
	3.2	F	G	H	H	-	E	F	G	H	H
	4.0	F	G	H	-	-	E	F	H	H	-
5.1	2.0	F	F	G	H	H	E	E	F	G	H
	3.0	F	G	H	H	-	E	F	G	H	H
	3.5	F	G	H	-	-	E	F	G	H	-
	4.0	G	G	H	-	-	E	F	H	H	-
5.4	2.0	F	F	G	H	H	E	E	F	G	H
	2.8	F	G	H	H	-	E	F	G	H	H
	3.0	F	G	H	-	-	E	F	G	H	-
	4.0	G	H	H	-	-	E	F	H	-	-
6.0	2.0	F	F	G	H	H	E	E	F	G	H
	2.8	F	G	H	H	-	E	F	G	H	H
	3.0	F	G	H	-	-	E	F	G	H	-
	4.0	G	H	H	-	-	E	F	H	-	-

8 WALLS

